



Suez Canal Road Tunnels Egypt



Construction
**PETROJET/CONCORD/CMS,
ARAB CONTRACTORS/
ORASCOM**

Consulting Engineers
**ACE MOHARRAM-BAKHOUM/
CDM-SMITH**

Owner
**ARMED FORCES
ENGINEERING AUTHORITY**

Project Type
HIGHWAY TUNNELS

Products Used
CONCENTRATE

Xypex Concentrate was used to stop water seepage in road tunnels under the Suez Canal.



Four new road tunnels under the Suez Canal promise to reduce travel time from days to minutes. The \$1 billion multi-tunnel project is part of a \$15 billion Sinai Peninsula economic development program.

In early January 2018, the last of four identical Herrenknecht Mixshield S-960 tunnel boring machines (TBMs) emerged from its 13.02 m (43 ft) diameter hole on the eastern bank of the Suez Canal. The 4.8 km (3 mile) tunnel is one of two tunnels dug side-by-side under the canal just north of Ismailia to create a new highway linking the Sinai Peninsula with Egypt's prosperous Nile Valley.

Two 2.8 km (1.7 mile) highway tunnels were also completed simultaneously south of Port Said. The four tunnels are each divided into two 3.75 m (12.3 ft) wide lanes. A total of 15.2 km (9.4 miles) of road tunnels were dug below the canal, reaching depths of more than 60 m (197 ft) and water pressure of more than 6 bar.

The \$1 billion multi-tunnel project, which also includes two railway tunnels, is a key part of the Egyptian government's \$15 billion plan to stimulate economic development in the impoverished Sinai region. The road and rail tunnels will make it easier and faster for people and goods to travel between the Sinai and the Egyptian homeland. Until the tunnels opened in the spring of 2019, vehicles were forced to wait days to cross the canal by ferry or wait in line for

hours at a single bridge and single tunnel. The four new road tunnels have reduced the canal crossing time to just 10 minutes.

A precast concrete segmental lining was installed in all four highway tunnels. Each lining ring consists of eight main segments and one key segment. Main segments measure 4 m long, 2 m wide, and 60 cm thick. More than 1.5 million cubic meters (1.96 million cu. yd.) of high strength concrete was used to cast more than 72,000 lining segments. Elastomeric gaskets were built into the lining segments to provide a watertight seal.

In 2018 and early 2019, as round-the-clock work continued on the Ismailia and Port Said tunnels in order to meet the target opening dates, water seepage was detected in some sections of the tunnels. With hydrostatic pressures of up to 6 bar, it is no wonder that some seepage was seen.

To solve this challenge, the contractors ordered 1,814 kg (4,000 lb) of Xypex Concentrate, based on a specification provided by Beton Waterproofing Services, of Alexandria, Egypt.



Four Herrenknecht Mixshield S-960 TBMs were used to simultaneously bore four two-lane highway tunnels under the Suez Canal in Egypt. Here, one of the TBMs emerges on the eastern shore of the canal south of Port Said, the northern most city along the canal.



Location of new highway tunnels under the Suez Canal, just south of Port Said, the canal's northern most access point. The tunnels join the Sinai Peninsula with the Egyptian homeland, just east of Cairo.

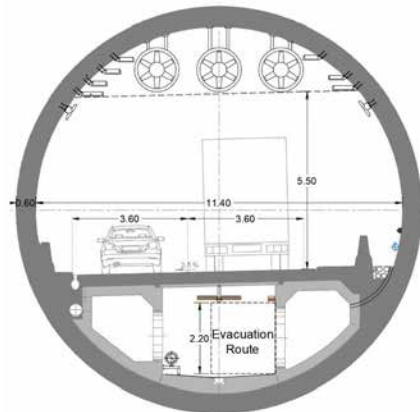

Road tunnels under the Suez Canal feature a single-layer precast concrete segmental lining with precast base platform elements to support the road deck and provide an evacuation route.



Nine precast concrete tunnel lining segments, required to create a single lining ring, await deployment into the tunnels.

“We provided a specification for the use of Xypex Concentrate to consultants ACE Moharram-Bakhoum,” notes Amr Saad, general manager for Beton, the Xypex distributor for Egypt. “We investigated several ways to apply the Xypex Concentrate to the joints to achieve optimal results. The Xypex crystalline waterproofing material needs time to diffuse into the concrete substrate. We modified our specification to recommend that the waterproofing contractors apply the Concentrate as a thick paste for best results.”

The active chemicals within Xypex Concentrate react with moisture and the constituents of hardened concrete to cause a catalytic reaction. This reaction generates a non-soluble crystalline formation throughout the pores and capillary tracts of the concrete that permanently seals the concrete and prevents the penetration of water and other liquids from any direction, even under high hydrostatic pressure.

Xypex Concentrate not only permanently seals the concrete and can heal hairline cracks up to 0.4 mm, it also provides chemical resistance properties that mitigate the attack of chlorides, sulfates and the effects of carbonation and alkali-aggregate reaction.

Four subcontractors, one each for the four highway tunnels, applied the Xypex Concentrate where needed. According to Amr Saad, approximately 95 percent or more of the seepage has been stopped using Xypex Concentrate.



Hundreds of precast concrete tunnel lining segments are stockpiled at the entrance to the Ismailia highway tunnels. The two-lane roadways will carry up to 50,000 vehicles per day in each direction.

“We are proud to have played a role in helping to provide the best possible waterproofing solution for this demanding application,” Saad says. “Our country is undergoing a tremendous cycle of construction and renewal. We are involved in many projects across Egypt where contractors and owners want a proven waterproofing solution. Xypex has been the leading crystalline waterproofing admixture, coating, and repair material around the world for more than 40 years.”